

# NT 01016

VKMA 01135 -  
VKMA 01136 -  
VKMA/C 01935 -  
VKMA/C 01936

Audi / Seat / Skoda / Volkswagen

VKMA 01935

VKMC 01935

VKMA 01936

VKMC 01936

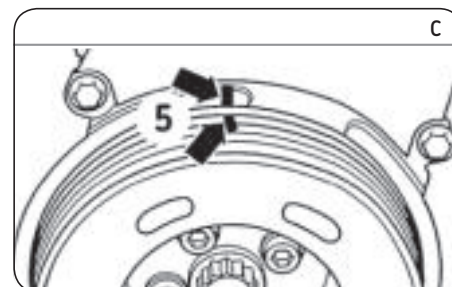
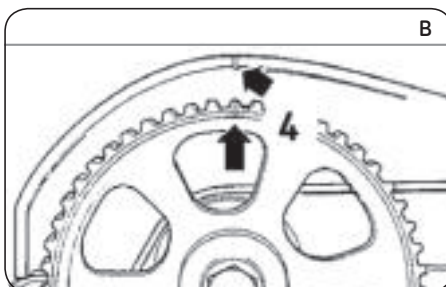
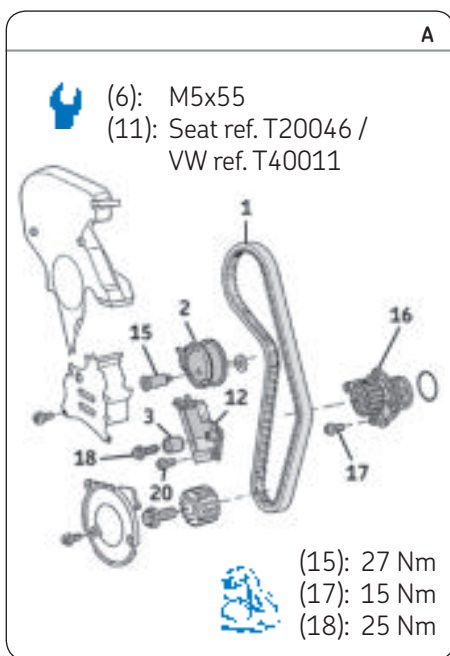

## Removal

- 1) Disconnect the battery according to the vehicle manufacturing guidelines.
- 2) Prepare the vehicle for the timing replacement according to the vehicle manufacturing guidelines.
- 3) Turn the crankshaft up to TDC on cylinder No.1. Check timing mark alignment:
  - (4) on the camshaft sprocket (Fig. B),
  - (5) on the crankshaft pulley (Fig. C),
  - (6) or (7) according to gearbox type: manual (Fig. D1) or automatic (Fig. D2).
- 4) Remove the crankshaft pulley and the lower timing casing.
- 5) Insert the stud (8) (M5 x 55mm long) together with a nut (9) and a washer (10) in the tensioner roller (2) (Fig. E). Loosen the tensioner roller fastening bolt (15) and tighten the nut (9) and washer (10) until a pin (11) can be inserted in the tensioning device (12) (Fig.E).
- 6) Remove the stud (8), the nut (9) and the washer (10) (Fig. E).
- 7) Remove the timing belt (1) and the tensioner roller (2).
- 8) If proceeding to fit kit **VKMA 01135** or **VKMA 01136**:
  - Remove the idler roller (3) (Fig. A).
- 9) If proceeding to fit kits **VKMA/C 01935** or **VKMA/C 01936**:
  - Remove the tensioning device (12) equipped with the stud (11) and the idler roller (3)(Fig. E).
- 10) **Removing the water pump (VKMC 01935/01936)**: firstly bleed the cooling circuit, check it is clean, and clean if required; secondly fully loosen the water pump fastening bolts (17) and remove the pump (16) (Fig. A)

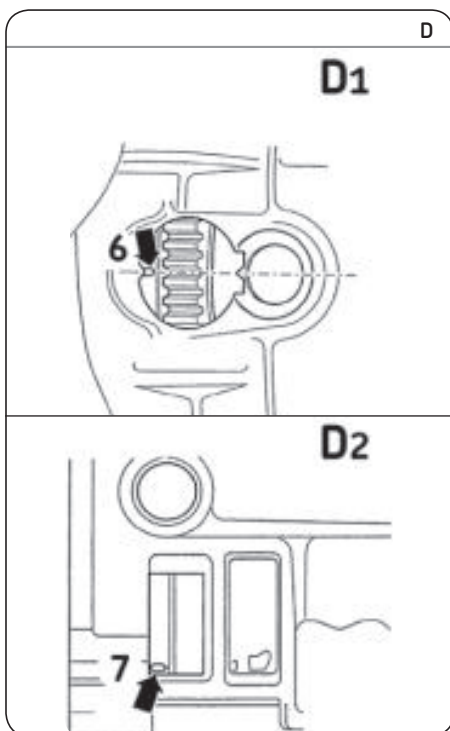

**Install Confidence**



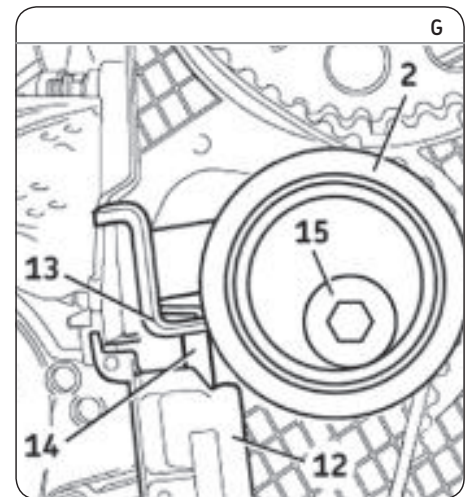
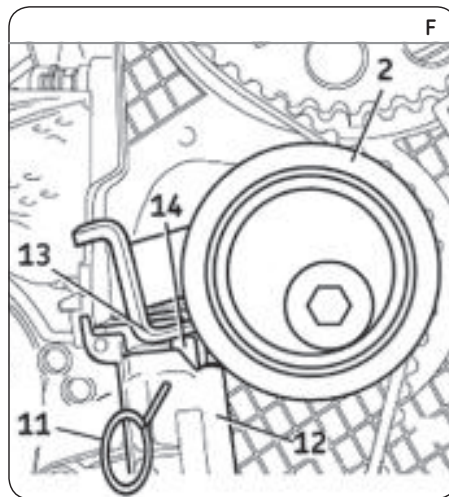
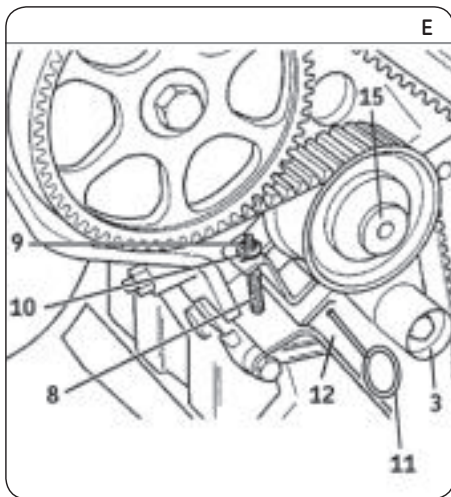

## Refitting

**Caution!** Clean the bearing surfaces of the rollers.

- 11) **Refitting the water pump:** Firstly fit the new water pump (16), apply the torque **15 Nm** to the waterpump bolts (17); then check that the water pump pulley runs properly, and has no hard or locking spots.
- 12) Check the alignment of timing marks (4) (Fig. B) and (6) or (7) (Fig. D1 and D2).
- 13) If proceeding to fit kits **VKMA/C 01935** or **VKMA/C 01936**:
  - Fit the new tensioning device (12) equipped with the stud (11) and the idler roller (3)(Fig.E). Tighten the 2 fastening bolts (20) (Fig. A).
- 14) If proceeding to fit kit **VKMA 01135** or **VKMA 01136**:
  - Fit the new idler roller (3). Tighten its new fastening bolt (18) to **25 Nm** (Fig. A).
- 15) Fit the new tension roller (2) and its new bolt (15).

**Note:** The rear plate (13) of the tensioner roller (2) must bear against the rod (14) of the tensioning device piston (12) (Fig. F).

- 16) Place the timing belt (1) on the crankshaft sprocket.
- 17) Refit the lower timing casing then the crankshaft pulley.
- 18) Continue refitting the belt (1) in the following order: water pump sprocket, idler roller (3), tensioner roller (2) and camshaft sprocket.
- 19) Check that the timing marks (5) are aligned (Fig. C).
- 20) Tighten the timing belt (1): remove the tension pin (11) (Fig. F) and allow the tensioning device piston (12) to act (Fig. G). Under the action of the piston rod (14), the tensioner roller moves and bears against the belt which tightens.
- 21) Tighten the fastening bolt (15) of the tensioner roller (2) to a torque of **27 Nm** (Fig. A and G).

- 22) Rotate the crankshaft **2 turns clockwise** up to TDC of cylinder No. 1. Check the alignment of timing marks (4) (Fig. B), (5) (Fig. C) and (6) or (7) (Fig. D1 and D2).
- 23) Refit the elements removed in reverse order to removal.
- 24) Fill the cooling circuit with the permanent fluid recommended.
- 25) Check the circuit's leak-tightness when the engine reaches its running temperature and secure the level of coolant when the engine is at ambient temperature (20 °C).

**Notice:** Always follow the vehicle manufacturer instructions when working on the engine. The SKF KITS are designed for the automotive repair professional and must be fitted using tooling used by these professionals. These instructions are to be used as a guideline only. This document is the exclusive property of SKF. Any representation, partial or full reproduction, is forbidden without prior written consent from SKF.